

Economical automatic labeling system.

Reliable Design

Weber's Alpha Compact label applicator is a cost-effective solution for fast, easy-to-use pressure-sensitive labeling. This system features a small footprint, yet employs a highly-accurate wipe-on method of application to affix pressure-sensitive labels to your products or packaging.

The Alpha Compact unit automatically unwinds the supply roll and peels the labels from their liner, then wipes them on to products, cartons and other packages as they travel past the system on a conveyor line.

Versatile Labeling

This system applies labels up to 4.7" wide and 11.8" long at speeds up to 164 feet per minute to a tolerance of ± 0.03 ".

The Alpha Compact can be oriented to apply labels to the sides, tops or bottoms of packages. To accommodate various production environments, it can be specified for right- or left-hand applications.

The integrated controller allows the Alpha Compact to store labeling settings such as start/stop, single label feed, speed control, sensor calibration and more. Using a PC computer, you can create settings and load them via a USB drive or with a Cat5 network connection.

Special Features

- Applies labels from 0.47" x 0.78" up to 4.7" wide x 11.8" long
- Operates at speeds up to 164 feet/minute
- Applies labels to the tops, bottoms or sides of packages
- Accurate labeling to within ± 0.03 "



Weber[®]
Packaging Solutions

Alpha Compact *General Specifications*

Dimensions

28.15" x 12.2" x 23.22"
(715mm x 310mm x 590mm)

Weight

48.5 lbs. (22kg)

Electrical

115/230 VAC, 47/63Hz

Product Sensing

Photoelectric

Label Roll Size

Up to 12" O.D. (300mm) wound on 3"
(76mm) core

Label Styling

Die-cut, waste-removed with a minimum of
0.125" (3mm) separation between labels in
running direction

Label Placement

Accurate to $\pm 0.03"$ (0.8mm) when labels
are produced to specifications and product
handling is controlled

Standard Label Sizes

Min width: 0.4" (10mm)
Max width: 4.7" (120mm)
Min length: 0.78" (20mm)
Max length: 11.8" (300mm)

Labeling Speed

Up to 164 fpm (50m) depending on label
roll width and diameter

Options

- Adjustable stand
- Encoder
- Low-label sensor
- Three-color stack light

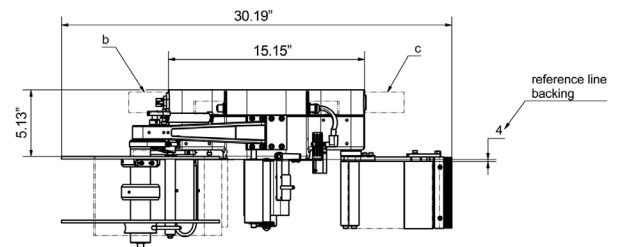
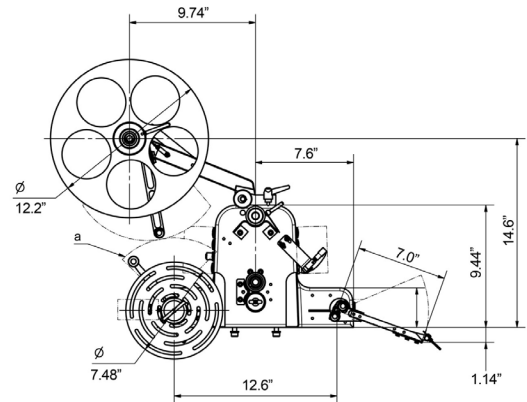
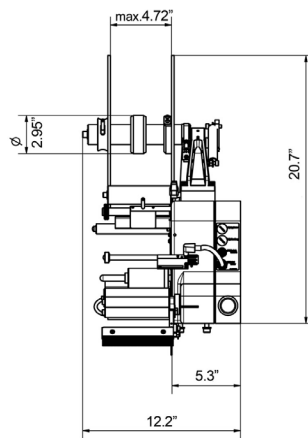

Three Interfaces

Depending upon the complexities and demands of the particular labeling operation, the Alpha Compact is available with three separate interfaces:

- Panel HMI includes an external operator's panel that provides system control through a pair of potentiometers and four push-buttons.
- Display HMI replaces the operator's panel with an LCD display that provides full access to all adjustment parameters.
- USB utilizes a USB connection that permits the unit to be configured from a PC.



Each version of the Alpha Compact features rugged die-cast aluminum construction, single-key calibration, automatic recognition of missing labels, in-production speed adjustment, and more.